



FEATURES

- Input Voltage Range :
Channel 1 : 3.4V to 5.5V
Channel 2 : 2.8V to 5.5V
- Low Quiescent Current is 50uA/per channel (typ.)
- Tight Load and Line Regulation
- Fast Transient Response
- Current Limit and Thermal Shutdown Protection
- Only low-ESR Ceramic Capacitors Required for Stability
- Available in the TO-252-5L Pb-Free Package

DESCRIPTION

The APE8840A is an efficient, precise dual-channel CMOS LDO regulator optimized for ultra-low-quiescent applications. Regulators output1 and output2 are capable of sourcing 700mA of output current. The regulators are stable with output capacitors as low as 1µF, including current limit, thermal shutdown protection, fast transient response, low dropout voltage, high output accuracy, current limiting protection, and high ripple rejection ratio. The APE8840A regulators are available in used TO-252-5L Pb-Free Package.

TYPICAL APPLICATION

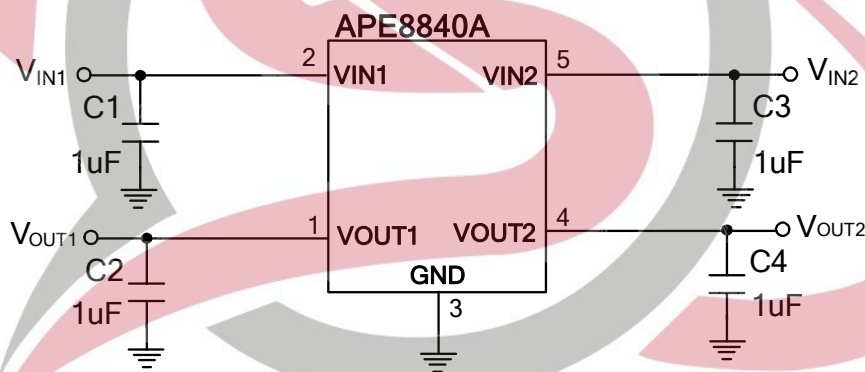

PACKAGE ORDERING INFORMATION

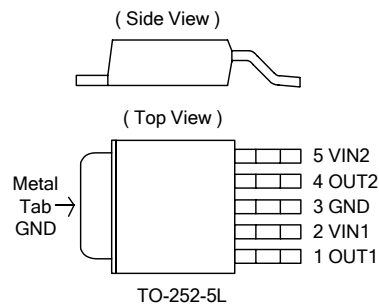
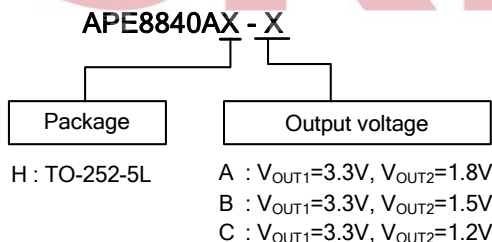



ABSOLUTE MAXIMUM RATINGS

V_{IN1}, V_{IN2} Pin Voltage ($V_{IN1,2}$)	6V
Output Voltage (V_{OUT1}/V_{OUT2})	GND - 0.3 to $V_{IN} + 0.3V$
Power Dissipation (P_D)	Internally Limited
Storage Temperature Range (T_{ST})	-65°C To 150°C
Operating Junction Temperature Range (T_{OPJ})	-40°C To + 125°C
Junction Temperature (T_J)	-40°C To + 150°C
Thermal Resistance from Junction to case (R_{thjc})	10°C/W
Thermal Resistance from Junction to ambient (R_{thja}) ^{Note}	30°C/W

Note: R_{thja} is measured with the PCB copper area of approximately 1 in²(Multi-layer). That need connect to tap pin.

ELECTRICAL SPECIFICATIONS

($V_{IN1} = V_{IN2} = 5V, T_A=25^\circ C$ (unless otherwise noted))

Parameter	SYM	TEST CONDITION	MIN	TYP	MAX	UNITS	
Input Voltage (Note1)	V_{IN1}	$I_{OUT1}=30mA$	3.4	-	5.5	V	
	V_{IN2}	$I_{OUT2}=30mA$	2.8	-	5.5		
Temperature Shutdown	$T_{SD1,2}$		-	150	-	°C	
Temperature Shutdown Hysteresis	$T_{SDR1,2}$		-	40	-	°C	
Regulator1							
Output Voltage Accuracy	V_{OUT1}	$I_{OUT1}=30mA$	3.234	3.3	3.366	V	
Output Voltage Temperature stability		$I_{OUT1}=10mA$ (Note4)	-	1	-	%	
Dropout Voltage	V_{DROP1}	$I_{OUT1}=700mA, V_{OUT1}=V_{OUT1}-2\%$	-	400	600	mV	
Quiescent Current	I_{Q1}	$I_{OUT1}=0mA, V_{IN1}=5V$	-	50	80	uA	
Line Regulation	V_{Line1}	$V_{IN1} = 4.3V$ to $5.5V, I_{OUT1} = 30mA$	-	0.1	0.2	%/V	
Load Regulation	ΔV_{LOAD}	$I_{OUT1} = 1m\sim 700mA$	-	10	40	mV	
Current Limit	I_{LIMIT1}	$V_{IN1} = 5.0V$	800	-	-	mA	
Short Circuit Current	I_{Short1}	$V_{OUT1} < 0.25 \times V_{OUT1}$	-	500	-	mA	
Ripple Rejection	PSRR1	$I_{OUT1} = 30mA, F=100Hz$	-	-60	-	dB	
Regulator2							
Output Voltage Accuracy	V_{OUT2}	$I_{OUT2}=30mA$ (APE8840AH-A)	1.764	1.8	1.836	V	
		$I_{OUT2}=30mA$ (APE8840AH-B)	1.47	1.5	1.53		
		$I_{OUT2}=30mA$ (APE8840AH-C)	1.176	1.2	1.224		
Output Voltage Temperature stability		$I_{OUT2}=10mA$	-	1	-	%	
Dropout Voltage	V_{DROP2}	$I_{OUT2}=700mA, V_{OUT2}=V_{OUT2}-2\%$	$V_{OUT}=1.2V$	-	1400	1600	mV
			$V_{OUT}=1.5V$	-	1100	1300	
			$V_{OUT}=1.8V$	-	800	1200	
Quiescent Current	I_{Q2}	$I_{OUT2} = 0mA, V_{IN2}=5V$	-	50	80	uA	
Line Regulation	V_{Line2}	$V_{IN2} = 2.8V$ to $5.5V, I_{OUT2} = 30mA$	-	0.1	0.2	%/V	
Load Regulation (Note3)	ΔV_{LOAD}	$I_{OUT2} = 1m\sim 700mA$	-	10	30	mV	
Current Limit (Note2)	I_{LIMIT2}	$V_{IN2} = 5.0V$	800	-	-	mA	
Short Circuit Current	I_{Short2}	$V_{OUT2} < 0.25 \times V_{OUT2}$	-	500	-	mA	
Ripple Rejection	PSRR2	$I_{OUT2} = 30mA, F=100Hz$	-	-60	-	dB	

Note1: The device is not guaranteed to function outside its operating conditions.

Note2: Current limit is measured at constant junction temperature by using pulsed testing with a low ON time.

Note3: Regulation is measured at constant junction temperature by using pulsed testing with a low ON time.

Note4: Guaranteed by design.



PIN DESCRIPTIONS

PIN SYMBOL	PIN DESCRIPTION
GND	Common Ground
VOUT1	Channel1 Output Voltage
VOUT2	Channel2 Output Voltage
VIN1	Channel1 input Voltage
VIN2	Channel2 input Voltage

BLOCK DIAGRAM

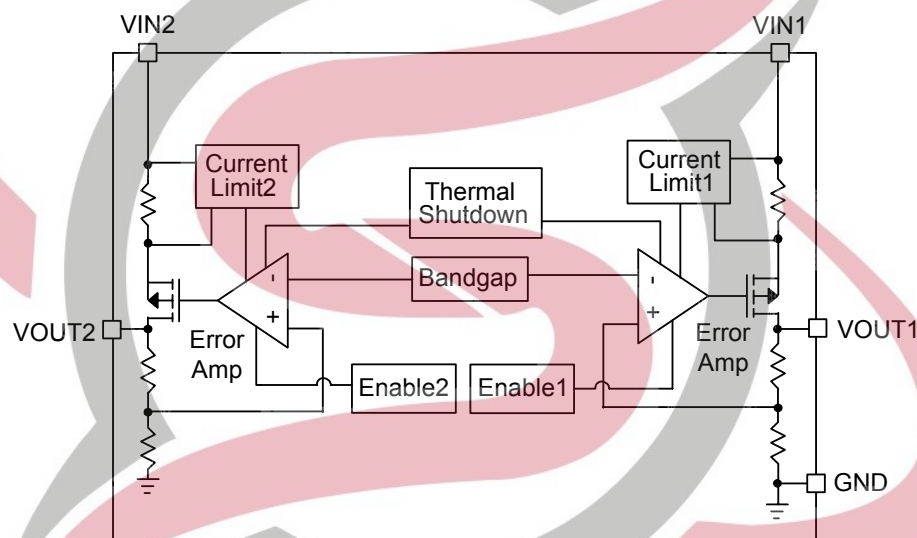

FUNCTION DESCRIPTIONS

The APE8840A is a highly accurate, dual, low noise, CMOS LDO voltage regulators with enable function. The output voltage for each regulator is set independently by fuse trimming. As illustrated in function block diagram, it consists of a reference, error amplifier, a P-channel pass transistor. The band gap reference is connected to the error amplifier, which compares the reference with the feedback voltage and amplifies the voltage difference. If the feedback voltage is lower than the reference voltage, the pass-transistor gate is pulled lower, which allows more current to pass to the VOUT pin and increases the output voltage. If the feedback voltage is too high, the pass transistor gate is pulled up to decrease the output voltage. The output voltage is feed back through an internal resistive divider connected to VOUT pin. Additional blocks include an output current limiter, thermal sensor, and shutdown logic.

Dropout Voltage

A regulator's minimum input-output voltage differential, or dropout voltage, determines the lowest usable supply voltage. The APE8840A use a P- channel MOSFET pass transistor, its dropout voltage is function of drain-to-source on-resistance $R_{DS(ON)}$ multiplied by the load current.

$$V_{DROPOUT} = V_{IN} - V_{OUT} = R_{DS(ON)} \times I_{OUT}$$



Current Limit

Each channel of APE8840A includes a fold back current limiter. It monitors and controls the pass transistor's gate voltage, estimates the output current, and limits the output current minimum 800mA.

Thermal Shutdown Protection

Thermal Shutdown protection limits total power dissipation of APE8840A. When the junction temperature exceeds $T_j = +150^{\circ}\text{C}$, a thermal sensor turns off the pass transistor, allowing the IC to cool down. The thermal sensor turns the pass transistor on again after the junction temperature cools down by 40°C , resulting in a pulsed output during continuous thermal shutdown conditions.

Thermal shutdown protection is designed to protect the APE8840A in the event of fault conditions. For continuous operation, the absolute maximum operating junction temperature rating of $T_j = +125^{\circ}\text{C}$ should not be exceeded.

Application Information

Like any low-dropout regulator, the APE8840A requires input and output decoupling capacitors. The device is specifically designed for portable applications requiring minimum board space and smallest components. These capacitors must be correctly selected for good performance (see Capacitor Characteristics Section). Please note that linear regulators with a low dropout voltage have high internal loop gains which require care in guarding against oscillation caused by insufficient decoupling capacitance.

Input Capacitor

An input capacitance of $1\mu\text{F}$ is required between input pin and ground directly (the amount of the capacitance may be increased without limit). The input capacitor must be located less than 1cm from the device to assure input stability. A lower ESR capacitor allows the use of less capacitance, while higher ESR type (like aluminum electrolytic) requires more capacitance. Capacitor types (aluminum, ceramic and tantalum) can be mixed in parallel, but the total equivalent input capacitance/ ESR must be defined as above to stable operation. There are no requirements for the ESR on the input capacitor, but tolerance and temperature coefficient must be considered when selecting the capacitor to ensure the capacitance will be $1\mu\text{F}$ over the entire operating temperature range.

Input Capacitor

The APE8840A is designed specifically to work with very small ceramic output capacitors. A ceramic capacitor (temperature characteristics X7R, X5R) in $1\mu\text{F}$ is suitable for the APE8840A application. The recommended minimum capacitance for the device is $1\mu\text{F}$, X5R or X7R dielectric ceramic, between VOUT and GND for stability, but it may be increased without limit. Higher capacitance values help to improve transient. The output capacitor's ESR is critical because it forms a zero to provide phase lead which is required for loop stability.



Thermal Considerations

The APE8840A series can deliver a current of up to 600mA/channel over the full operating junction temperature range. However, the maximum output current must be debated at higher ambient temperature to ensure the junction temperature does not exceed 125°C. With all possible conditions, the junction temperature must be within the range specified under operating conditions. Power dissipation can be calculated based on the output current and the voltage drop across regulator.

$$P_D = (V_{IN} - V_{OUT}) I_{OUT} + V_{IN} I_{GND}$$

The final operating junction temperature for any set of conditions can be estimated by the following thermal equation:

$$P_{D(MAX)} = (T_{J(MAX)} - T_A) / \theta_{JA}$$

Where $T_{J(MAX)}$ is the maximum junction temperature of the die (125° C) and T_A is the maximum ambient temperature. The junction to ambient thermal resistance (θ_{JA}) TO-252-5L package at recommended minimum footprint is 30°C/W that is connect 1 in2 PCB copper area to exposed pad.





TYPICAL PERFORMANCE CHARACTERISTICS

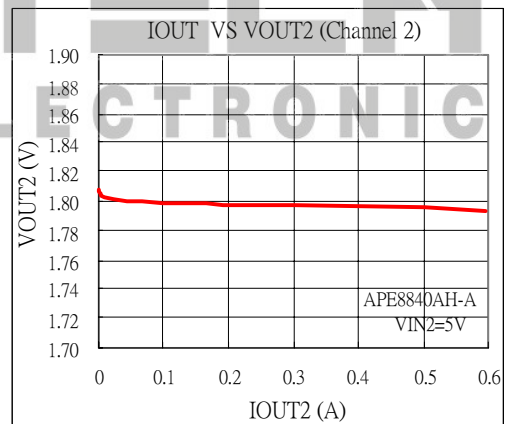
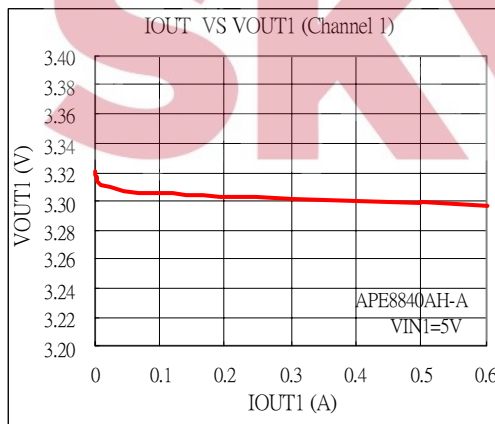
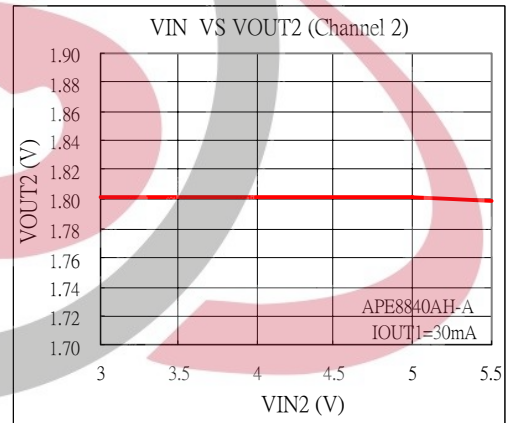
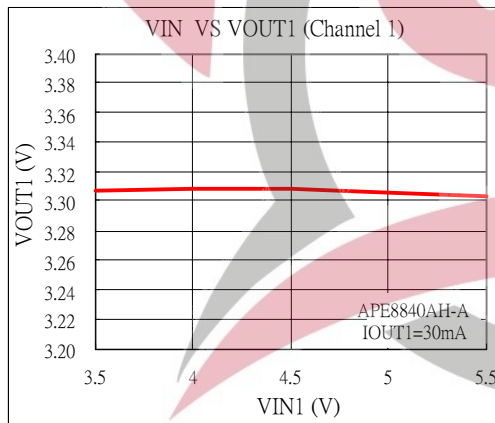
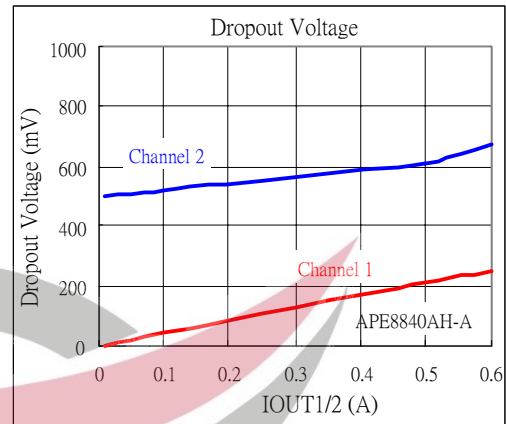
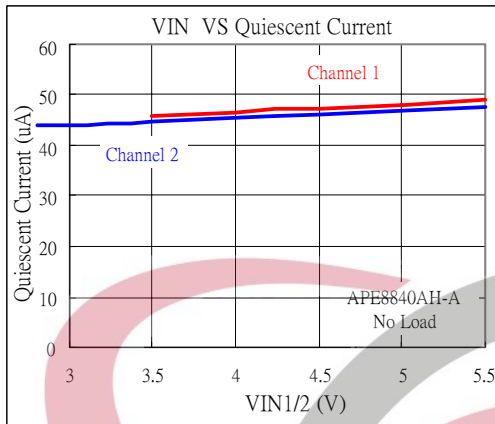



TYPICAL PERFORMANCE CHARACTERISTICS

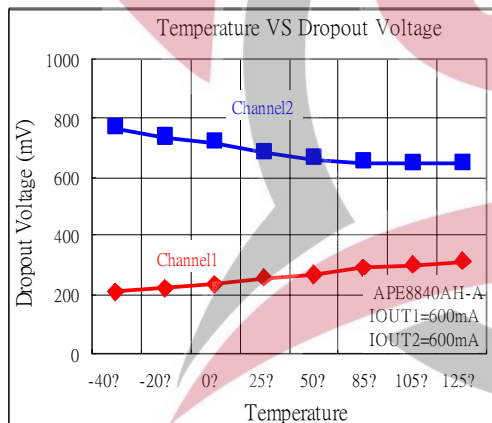
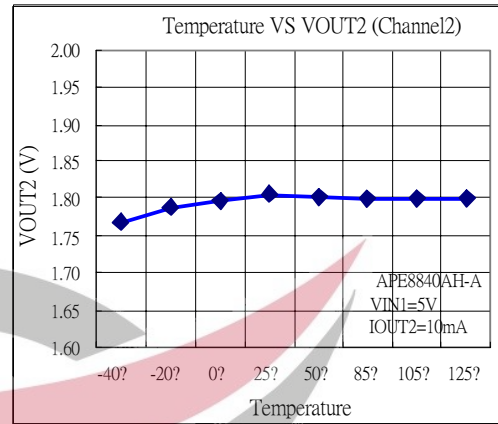
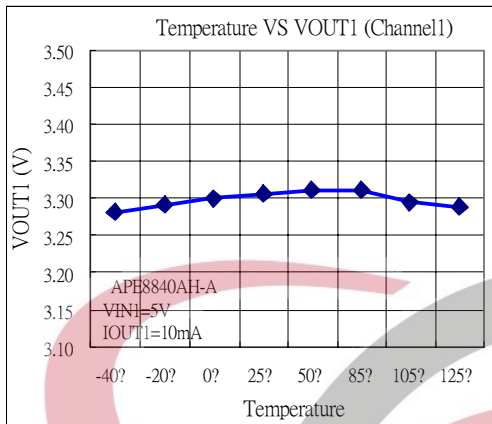



TYPICAL PERFORMANCE CHARACTERISTICS

Power ON Test (Channel1)

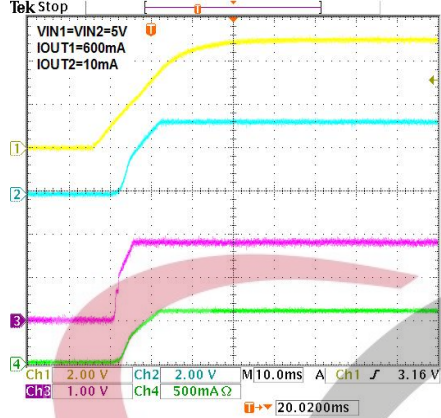

Power ON Test (Channel2)

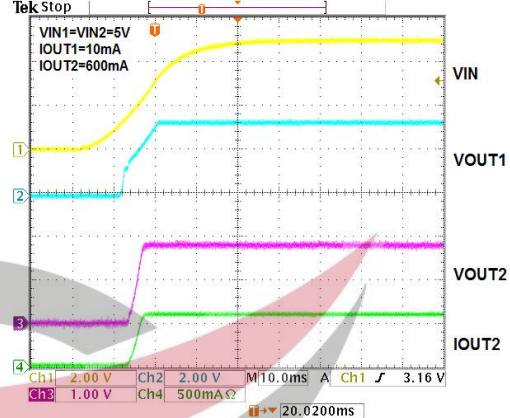

Load Transient (Channel 1)

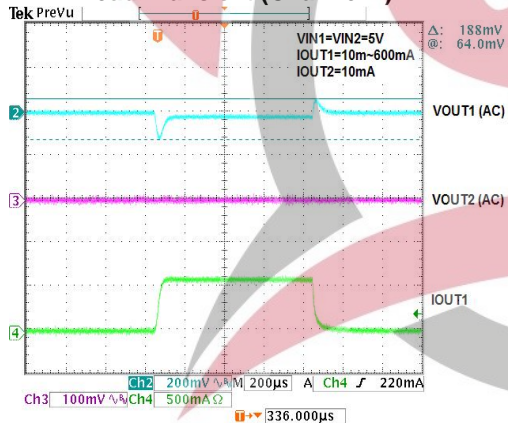

Load Transient (Channel 2)

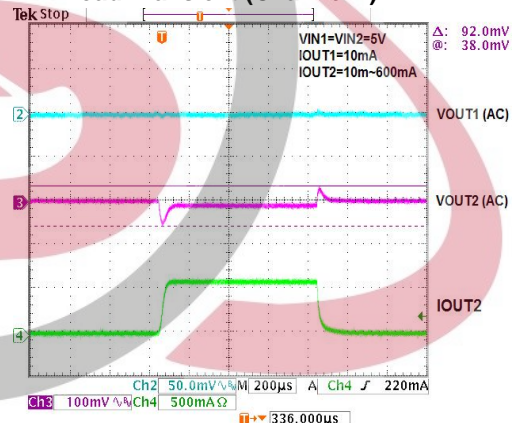

SKYTECH
ELECTRONIC



Package Outline : TO-252(5L)

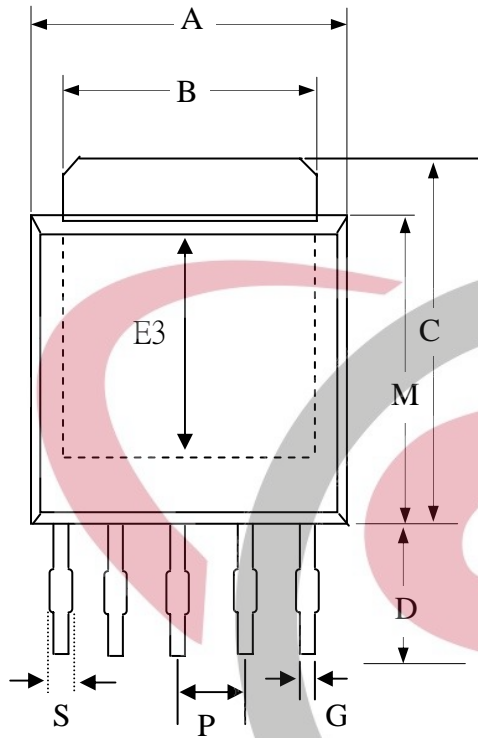

SYMBOLS	Millimeters		
	MIN	NOM	MAX
A	6.40	6.60	6.80
B	5.20	5.35	5.50
C	6.80	7.00	7.20
D	2.20	2.50	2.80
P	1.27 REF.		
S	0.50	0.65	0.80
E3	3.50	4.00	4.50
G	0.40	0.50	0.60
H	2.20	2.30	2.40
J	0.45	0.50	0.55
K	0.00	0.08	0.15
L	0.90	1.20	1.50
M	5.40	5.60	5.80

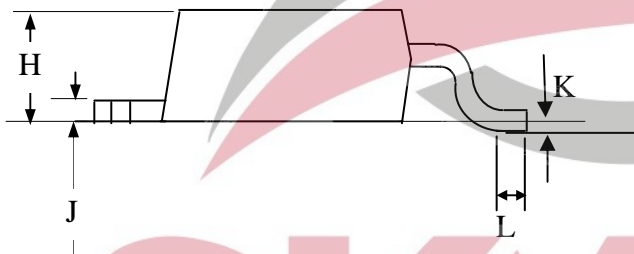

- 1.All Dimensions Are in Millimeters.
- 2.Dimension Does Not Include Mold Protrusions.

Part Marking Information & Packing : TO-252(5L)

Laser Marking .

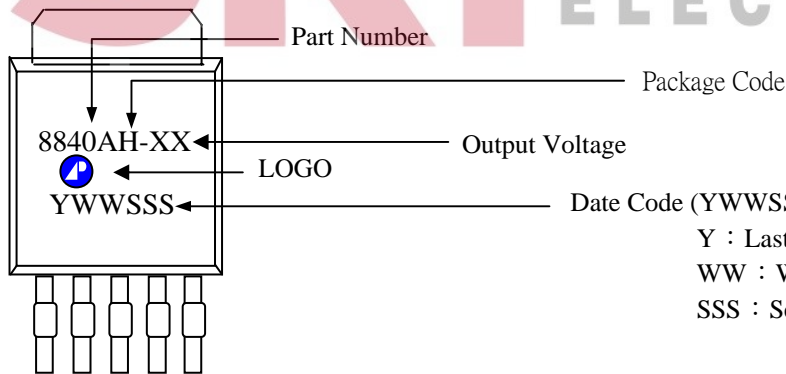

Date Code (YWWSSS)
Y : Last Digit Of The Year
WW : Week
SSS : Sequence